

NXQ1TXA1

Qi standard conforming charger controller

Rev. 1 — 13 March 2014

Objective data sheet

1. General description

The NXQ1TXA1 is a state of the art digital control controller for Qi-standard conforming wireless charger base stations. The controller supports type A1 or A10 single coil base stations.

The NXQ1TXA1 offers wireless power transfer, WPC 1.1 - Qi low power standard - compliant communication and safety functions including Foreign Object Detection (FOD), temperature monitoring and more. The controller supports the conventional WPC pinging mode during standby to identify potential receivers and also works with the NXP NFC TAGs to enabled by e.g. a NFC enabled phone so that the charger supports a zero power standby mode. The controller also offers a flexible User Interface (UI) with up to two LEDs and one buzzer for feedback and control.

Depending on the required charging pad area, coil configurations such as A1 (single coil with magnet) and A10 (single coil without magnet) are supported.

2. Features and benefits

- Qi conforming wireless charger controller and communication:
 - ◆ Integrated Foreign Object Detection (FOD)
 - ◆ Using frequency and duty cycle control
 - ◆ ASK demodulation
 - ◆ 1 NTC input for coil or surface temperature monitoring
- 2 LED outputs for optical user feedback
- Buzzer output for acoustical user feedback
- Integrated PMU (Power Management Unit) to minimize power consumption during Sleep and power-down modes using tap to power-on
- Tap to power-on option in combination with NT3H1201 (NFC TAG)
- HVQFN33 package, 7 x 7 x 0.85 mm

3. Applications

- Wireless Power Consortium version 1.1 (Qi) conforming base station for charging of mobile devices

4. Ordering information

The NXP WPC/Qi charging transmitter application uses NXP and non-NXP components to offer an optimized system solution in terms of performance and cost.



All NXP components used are listed in [Table 1](#) while the non-NXP semiconductor components are summarized in [Table 2](#).

Table 1. Ordering information, NXP semiconductor components

Type number	Function	Package		Order information
		Name	Description	12NC
NXQ1TXA1/001	Wireless charger controller	HVQFN33	HVQFN: plastic thermal enhanced very thin quad flat package; no leads; 33 terminals; body 7 × 7 × 0.85 mm	9353 039 25551
NWP2081T	Half-bridge level-shift IC	SOT96-1	plastic small outline package; 8 leads	9353 021 87518
NX2020N2	30 V, single N-channel Trench MOSFET	SOT1220	plastic thermal enhanced ultra thin small outline package; no leads; 6 terminals	9340 682 45115
BC847C	45 V, 100 mA NPN general-purpose transistors	SOT23	plastic surface-mounted package; 3 leads	9335 896 00215
BAS101S	High-voltage switching diodes	SOT23	plastic surface-mounted package; 3 leads	9340 608 49215
BAT54S	Schottky barrier diodes	SOT23	plastic surface-mounted package; 3 leads	9339 763 80215
BAT54C	Schottky barrier diodes	SOT23	plastic surface-mounted package; 3 leads	9339 763 70215
Optional				
NT3H1201	NTAG-I2C NFC forum tag 2 type compliant IC with I2C interface	XQFN8	plastic, extremely thin quad flat package; no leads; 8 terminals; body 1.6 x 1.6 x 0.5 mm	9353 028 43125
NX2020P1	30 V, single P-channel Trench MOSFET	SOT1220	plastic thermal enhanced ultra thin small outline package; no leads; 6 terminals	9340 682 44115
NX3008NBKW	30 V, N/P-channel Trench MOSFET	SOT323	plastic surface-mounted package; 3 leads	9340 656 35115
NX3008CBKS	30 V, single N-channel Trench MOSFET	SOT363	plastic surface-mounted package; 3 leads	9340 656 39115
TDA3663	LDO (or use DC/DC RT8295A)	SOT223	plastic surface-mounted package with increased heat-sink; 4 leads	9352 629 68135
TEA1720BT/1	SMPS controller	SOT96-1	plastic small outline package; 8 leads	9353 021 95118

Table 2. Ordering information, non-NXP semiconductor components

Type number	Function	Package		
		Name	Description	Version
MAX9634HEUK	current shunt monitor	SSOT753		
RT8295A	DC-DC converter (or use LDO TDA3663)	SOP-8	Voltage regulator with > 24 V input and 3.3 V output	

5. Block diagram

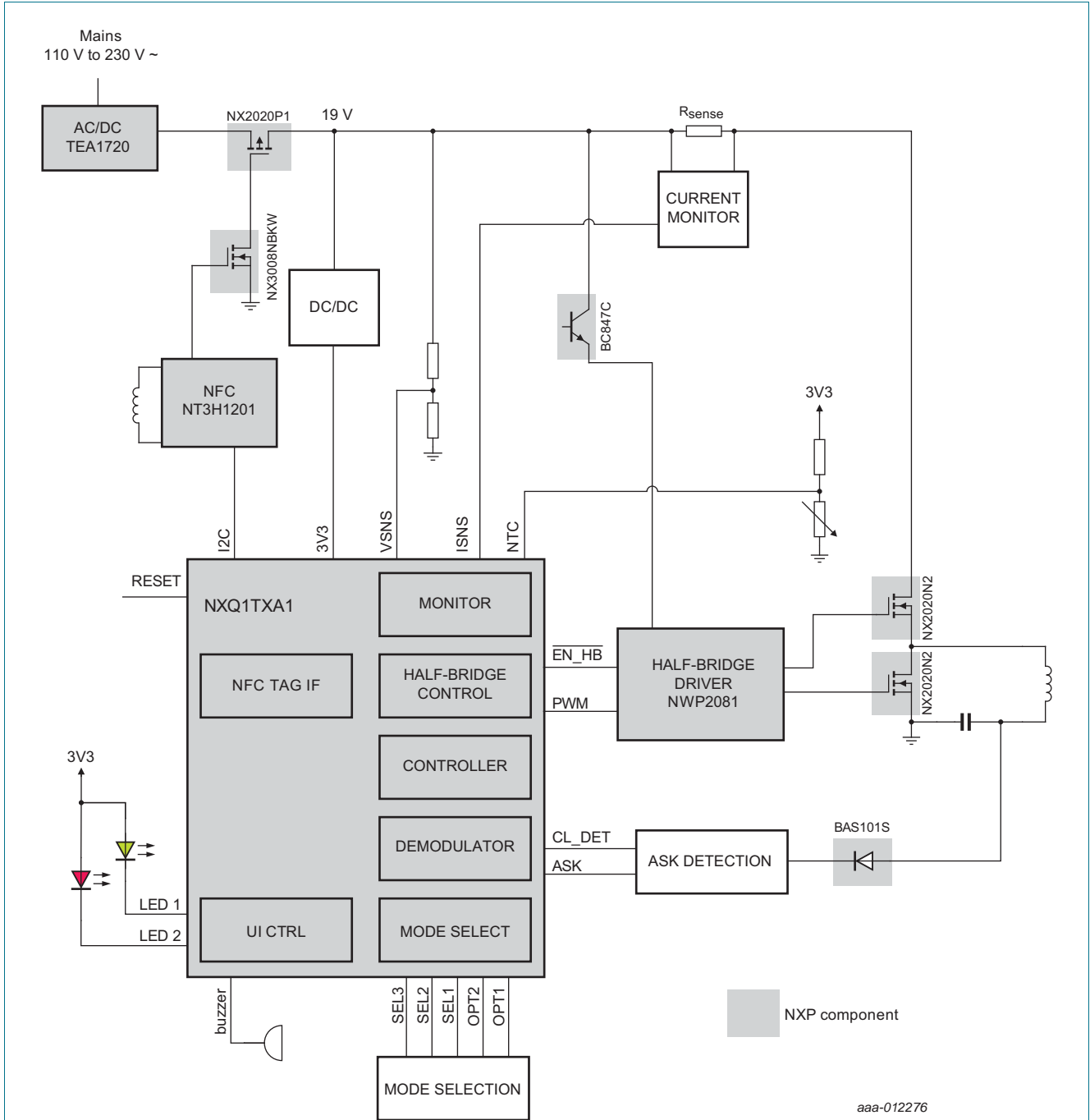

The block diagram does not depict all semiconductor components used to build up the system. Please see the related application note for details.

The NXQ1TXA1/001 supports A1 or A10 single coil chargers only.

Fig 1. NXQ1TXA1 based Qi compliant charger block diagram, A1/10 (1-coil) design with NFC wake-up

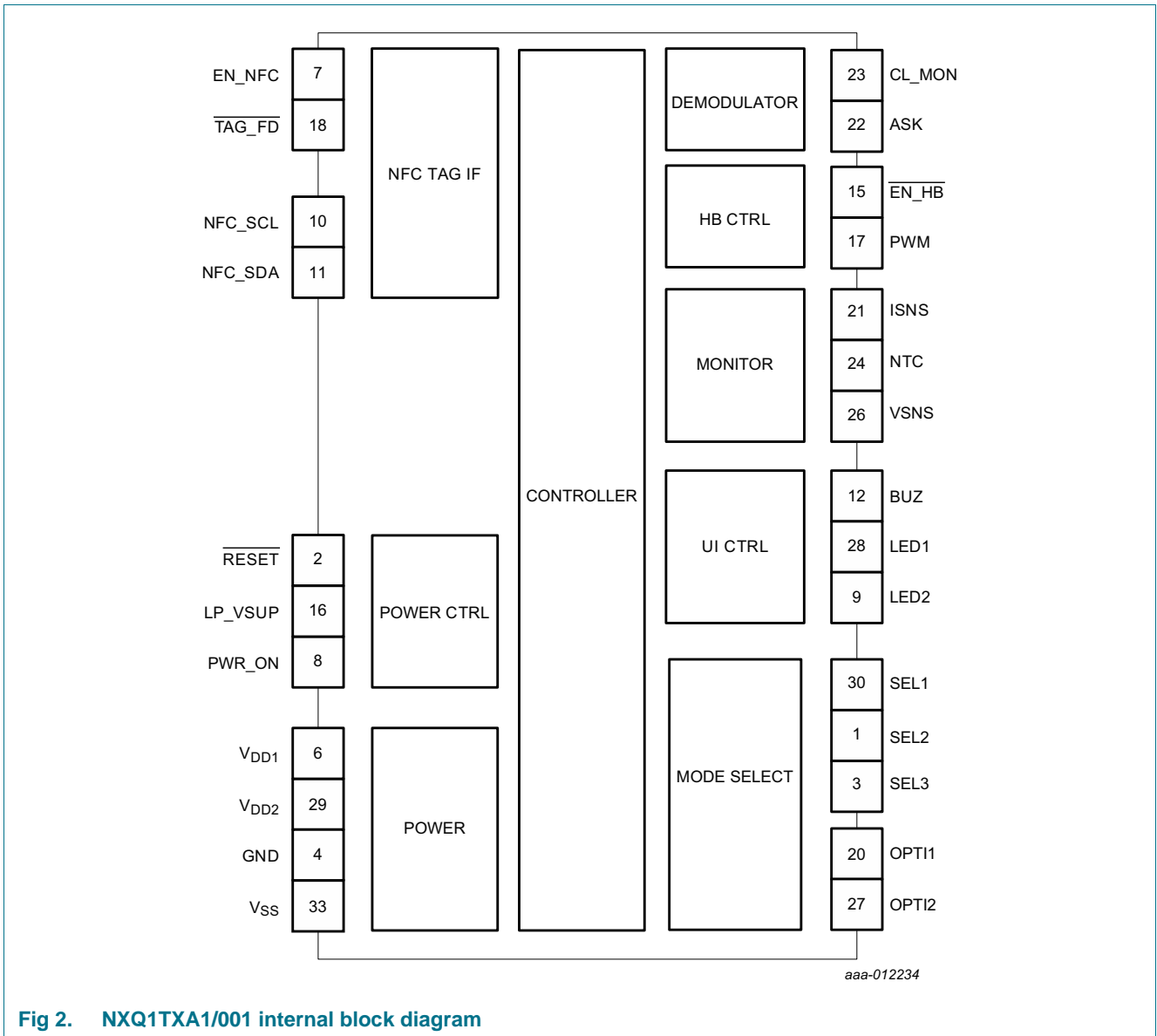
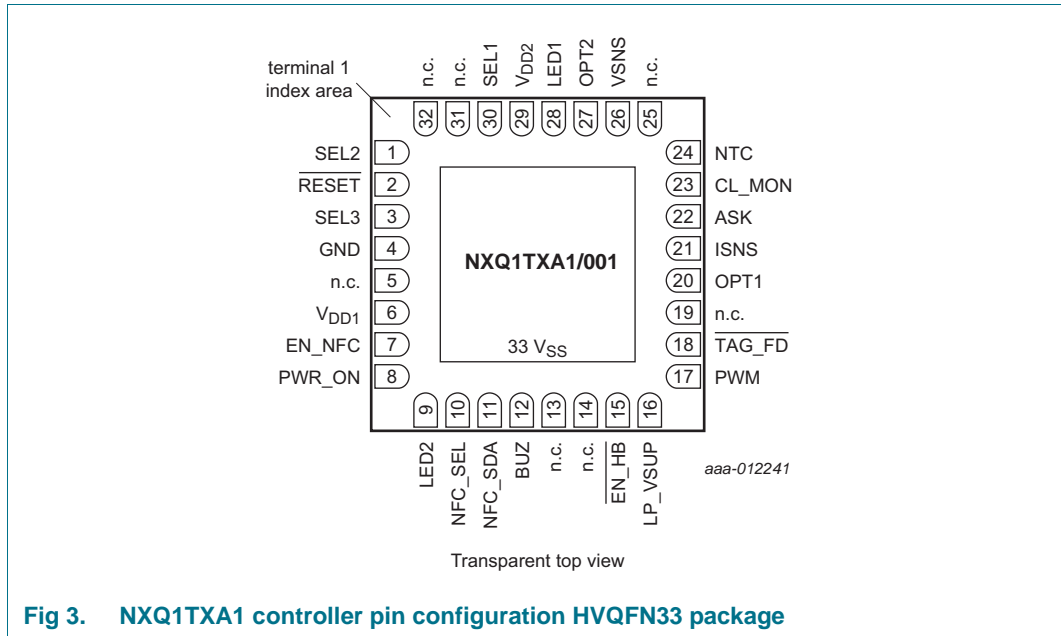

Fig 2. NXQ1TXA1/001 internal block diagram

6. Pinning information

6.1 Pinning



6.2 Pin description

Table 3. NXQ1TXA1 pin description table

Symbol	Pin	Description
$\overline{\text{RESET}}$	2	RESET — External reset input with 20 ns glitch filter. A LOW-going pulse as short as 50 ns on this pin resets the device.
PWR_ON	8	PWR_ON — power on signal
NFC_SCL	10	NFC_SCL — NFC Tag I ² C-bus, open-drain clock input
NFC_SDA	11	NFC_SDA — NFC Tag I ² C-bus, open-drain data input/output
$\overline{\text{TAG_FD}}$	18	TAG_FD — field detect
EN_NFC	7	EN_NFC — NFC tag enable control output
$\overline{\text{EN_HB}}$	15	EN_HB — Half-bridge enable control
LP_VSUP	16	LP_VSUP — switched low power voltage supply
PWM	17	PWM — Half-bridge PWM control
VSNS	26	VSNS — Supply voltage monitor input
ISNS	21	ISNS — Current sense monitor input
ASK	22	ASK — ASK demodulator signal input
CL_MON	23	CL_MON — coil voltage monitor
NTC	24	NTC — NTC input pin
OPT1	20	OPT1 — Option select 1 input
OPT2	27	OPT2 — Option select 2 input
SEL1	30	SEL1 — Select 1 pin
SEL2	1	SEL2 — Select 2 pin
SEL3	3	SEL3 — Select 3 pin
LED1	28	LED1 — LED 1 open drain pull-down pin
LED2	9	LED2 — LED 2 open drain pull-down
BUZ	12	BUZ — Buzzer open drain driver input/output pin
V _{DD}	6; 29	V_{DD} — 3.3 V supply voltage input
V _{SS}	33	V_{SS} — GND and thermal pad; connect to GND
GND	4	reserved - connect to GND
n.c.	5, 13, 14, 19, 25, 31, 32	n.c. — no connect; do NOT connect to GND

7. Functional description

7.1 Functional overview

The NXQ1TXA1 is a wireless charging controller for usage in a base station with a single primary coil. It is intended to create a type A1 or type A10 power transmitter as defined by the Qi low power specification v.1.1.2 of the Wireless Power Consortium.

As shown in [Figure 1](#) using the NXQ1TXA1 IC in combination with a power stage, consisting of a half bridge driver ([NWP2081T](#)) and two MOSFETs (NX2020N2), creates a magnetic coupled power transmitter.

The charging controller takes care of all intelligence involved to create a wireless charging transmitter. This includes the control signals PWM and EN_HB to drive a power stage, the analog inputs ASK and CL_MON for detection and communication, and an optional NTC input for over temperature protection.

A separate current monitor is used to enable foreign object detection and a discrete envelope detector circuit is use to re-construct the 2 kHz ASK communication waveform as used by Qi.

At startup the controller will sense the OPTx inputs to determine the functionality of the connected LEDs and Buzzer. The SELx pins will be read out to select the settings for Foreign Object Detection. The transmitter implements four phases, as defined by the Qi standard, for power transfer from a base station to a mobile device: selection, ping, identification & configuration and power transfer. The transitions between these four phases are done according to the Qi specification.

7.2 Configuration options

The NXQ1TXA1 supports multiple mode of operation for the user interface comprised of two LEDs and one Buzzer. It supports several blinking code variations for the LEDs in combination with buzzer tones. The UI mode of operation is set by the voltage level at pin OPT1 at startup. To set the level at the pin OPT1 a voltage divider can be used as depicted in [Figure 4](#).

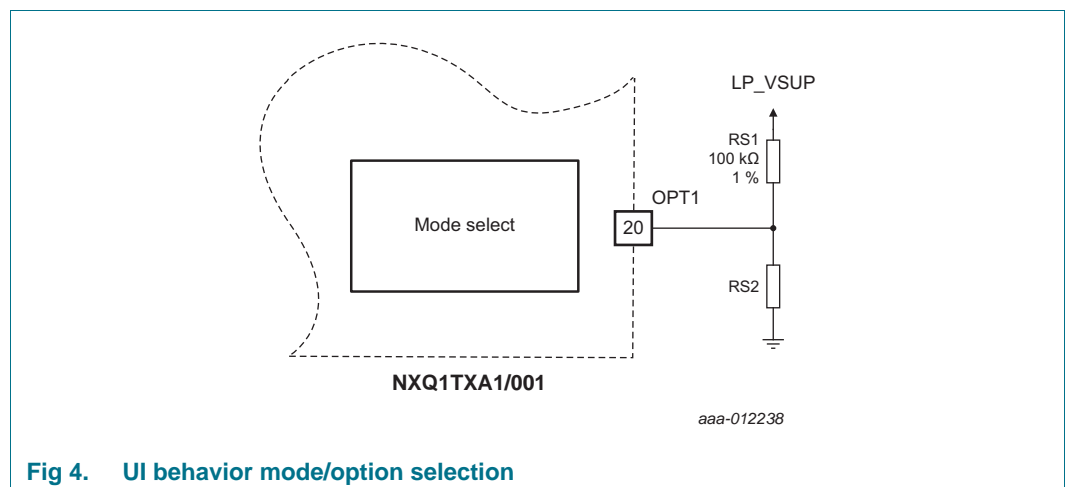

Fig 4. UI behavior mode/option selection

The various settings possible are summarized in [Table 4](#)

Table 4. UI behavior selection

RS1 (k Ω , 1 %)	RS2 (k Ω , 1 %)	Mode number	LED	Standby	Charging	Charge complete	FOD	Temp. error	Receiver indicator error
100.0	14.3	0	reserved	reserved	reserved	reserved	reserved	reserved	reserved
			reserved	reserved	reserved	reserved	reserved	reserved	reserved
100.0	23.2	1	reserved	reserved	reserved	reserved	reserved	reserved	reserved
			reserved	reserved	reserved	reserved	reserved	reserved	reserved
100.0	33.2	2	reserved	reserved	reserved	reserved	reserved	reserved	reserved
			reserved	reserved	reserved	reserved	reserved	reserved	reserved
100.0	45.3	3	reserved	reserved	reserved	reserved	reserved	reserved	reserved
			reserved	reserved	reserved	reserved	reserved	reserved	reserved
100.0	60.4	4	reserved	reserved	reserved	reserved	reserved	reserved	reserved
			reserved	reserved	reserved	reserved	reserved	reserved	reserved
100.0	78.7	5	reserved	reserved	reserved	reserved	reserved	reserved	reserved
			reserved	reserved	reserved	reserved	reserved	reserved	reserved
100.0	100.0	6	LED1	Off	Off	Off	3 Hz blink	3 Hz blink	3 Hz blink
			LED2	Off	1 Hz blink	ON	Off	Off	Off

7.3 Safety features

The NXQ1TXA1 contains three different safety functions to protect the user, the charger itself and also the mobile device to be charged.

The foreign object detection constantly evaluates whether significant amounts of power are absorbed by devices not being related to the power receiver used for charging. A thermal protection is used to monitor the base station and the coil temperature. Additionally the controller will stop the power transfer if the receiver indicates an end of power.

7.3.1 Foreign Object Detection

The Foreign Object Detection (FOD) implemented in the NXQ1TXA1 is constantly comparing the base station input power with the mobile side received power packet information to calculate losses to foreign objects that are not accounted for in the transmitter or receiver. Once the power transfer is stopped due to a foreign object being detected, the base station will wait until the receiver is removed.

When the mobile device is placed back on the power transmitter unit, the NXQ1TXA1 will resume normal operation. In case the power consuming foreign object is still present (or e.g. a mobile device is malfunctioning), the procedure as described before will be executed again. The FOD threshold is set by the voltage level at pin OPT2.

The OPT2 input is being multiplexed and a voltage divider as depicted in [Figure 5](#) can be used.

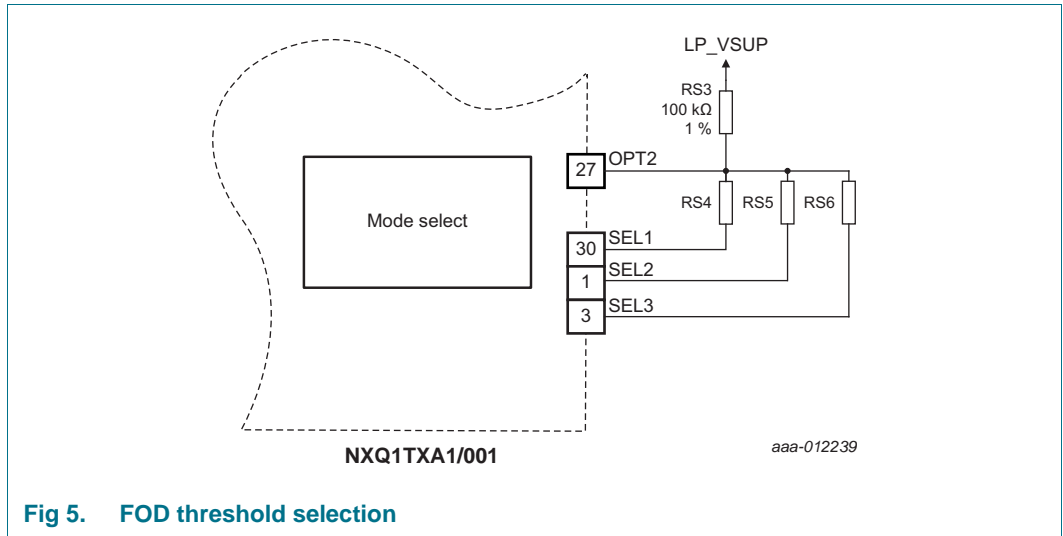

Fig 5. FOD threshold selection

The resistors RS3 and RS4 are used in conjunction with the SEL1 signal to determine the FOD threshold. The resistor settings are as in [Table 5](#).

Table 5. FOD level selection

RS3 (kΩ, 1 %)	RS4 (kΩ, 1 %)	Foreign Object Detection threshold (mW)
100.0	n.c.	disabled
100.0	6.7	150
100.0	14.3	200
100.0	23.2	250
100.0	33.2	300
100.0	45.3	350
100.0	60.4	400
100.0	78.7	450
100.0	100.0	500
100.0	127.0	550
100.0	165.0	600
100.0	221.0	650
100.0	301.0	700
100.0	432.0	750
100.0	698.0	800
100.0	1500.0	850

Table 6. WPC1.0 receiver power threshold

RS3 (kΩ, 1 %)	RS5 (kΩ, 1 %)	Receiver power threshold (mW)
100.0	n.c.	reserved
100.0	6.7	reserved
100.0	14.3	reserved
100.0	23.2	reserved
100.0	33.2	reserved
100.0	45.3	reserved
100.0	60.4	reserved
100.0	78.7	reserved
100.0	100.0	reserved
100.0	127.0	reserved
100.0	165.0	reserved
100.0	221.0	reserved
100.0	301.0	reserved
100.0	432.0	reserved
100.0	698.0	reserved
100.0	1500.0	reserved

7.3.2 Thermal protection

The voltage at pin NTC is sensed to enable the over temperature protection. If the voltage at pin NTC rises above the high threshold value the transmitters stops the power transfer phase and resumes when the NTC pin voltage is below the low threshold value. When the transmitter resumes it starts with the Qi selection phase again. The voltage to pin NTC can be created as shown in [Figure 6](#).

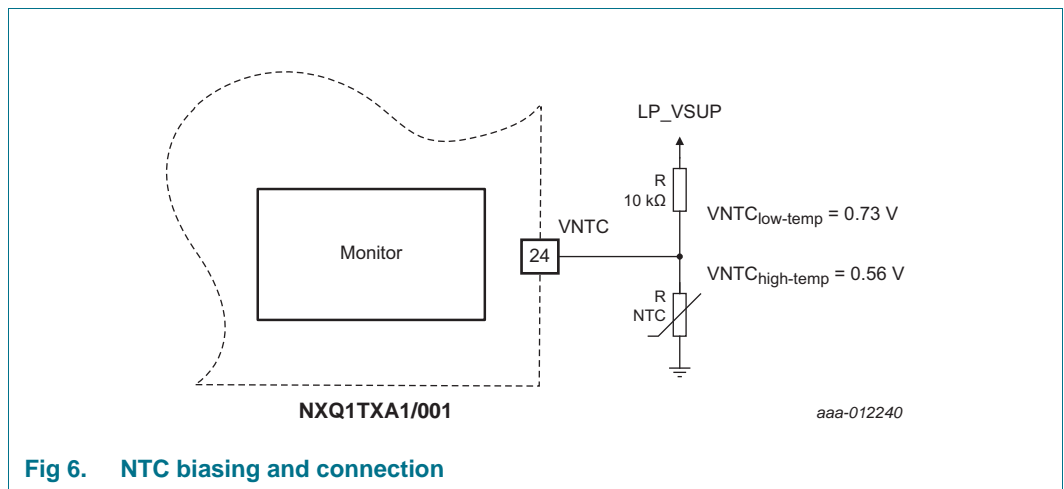

Fig 6. NTC biasing and connection

7.3.3 Receiver end power transfer

If the active Qi receiver signals a valid end of power transfer packet, the transmitter will respond according to [Table 7](#).

Table 7. End power transfer value

Reason	Value	base station response
Unknown	0x00	goes to selection phase
Charge Complete	0x01	stop power transfer
Internal Fault	0x02	stop power transfer and waits for device removal
Over Temperature	0x03	stop power transfer and waits for device removal
Over Voltage	0x04	goes to selection phase
Over Current	0x05	goes to selection phase
Battery Failure	0x06	stop power transfer and waits for device removal
Reconfigure	0x07	goes to identification phase
No Response	0x08	goes to selection phase
Reserved	0x09 ... 0xFF	stop power transfer and waits for device removal

8. Limiting values

Table 8. Limiting values

In accordance with the Absolute Maximum Rating System (IEC 60134).^[1]

Symbol	Parameter	Conditions	Min	Max	Unit
V _{DD}	supply voltage (core and external rail)		-0.5	+0.6	V
V _I	input voltage	5 V tolerant I/O pins; only valid when the V _{DD} supply voltage is present	-0.5	+5.5	V
		5 V tolerant open-drain pins	-0.5	+5.5	V
V _{IA}	analog input voltage	pins ISNS, VSNS, NTC, ASK, CL_MON, OPTx	-0.5	+4.6	V
I _{DD}	supply current	per supply pin	-	100	mA
I _{SS}	ground current	per ground pin	-	100	mA
I _{latch}	I/O latch-up current	$-(0.5V_{DD}) < V_I < (1.5V_{DD})$; T _j < 125 °C	-	100	mA
T _{stg}	storage temperature	non-operating	-65	+150	°C
T _{j(max)}	maximum junction temperature		-	150	°C
P _{tot(pack)}	total power dissipation (per package)	based on package heat transfer, not device power consumption	-	1.5	W
V _{ESD}	electrostatic discharge voltage	human body model; all pins		+6500	V

[1] The following applies to the limiting values:

- This product includes circuitry specifically designed for the protection of its internal devices from the damaging effects of excessive static charge. Nonetheless, it is suggested that conventional precautions be taken to avoid applying greater than the rated maximum.
- Parameters are valid over operating temperature range unless otherwise specified. All voltages are with respect to V_{SS} unless otherwise noted.
- The limiting values are stress ratings only. Operating the part at these values is not recommended, and proper operation is not guaranteed. The conditions for functional operation are specified in [Table 11](#).

[2] Maximum/minimum voltage above the maximum operating voltage (see [Table 11](#)) and below ground that can be applied for a short time (< 10 ms) to a device without leading to irrecoverable failure. Failure includes the loss of reliability and shorter lifetime of the device.

[3] V_{DD} present or not present. Compliant with the I²C-bus standard. 5.5 V can be applied to this pin when V_{DD} is powered down.

[4] The maximum non-operating storage temperature is different than the temperature for required shelf life which should be determined based on required shelf lifetime. Please refer to the JEDEC spec (J-STD-033B.1) for further details.

[5] Human body model: equivalent to discharging a 100 pF capacitor through a 1.5 kΩ series resistor.

9. Thermal characteristics

The average chip junction temperature, T_j (°C), can be calculated using the following equation:

$$T_j = T_{amb} + (P_D \times R_{th(j-a)}) \tag{1}$$

- T_{amb} = ambient temperature (°C),
- $R_{th(j-a)}$ = the package junction-to-ambient thermal resistance (°C/W)
- P_D = sum of internal and I/O power dissipation

The internal power dissipation is the product of I_{DD} and V_{DD} . The I/O power dissipation of the I/O pins is often small and many times can be negligible.

Table 9. Thermal characteristics

$V_{DD} = 3.0\text{ V to }3.6\text{ V}$; $T_{amb} = -40\text{ °C to }+85\text{ °C}$ unless otherwise specified.

Symbol	Parameter	Conditions	Min	Typ	Max	Unit
$T_{j(max)}$	maximum junction temperature		-	-	125	°C

Table 10. NXQ1TXA1 Thermal resistance value (C/W): ±15 %

$V_{DD} = 3.0\text{ V to }3.6\text{ V}$; $T_{amb} = -40\text{ °C to }+85\text{ °C}$ unless otherwise specified.

HVQFN33	
θ_{ja}	
JEDEC (4.5 in × 4 in)	
0 m/s	40.4
1 m/s	32.7
2.5 m/s	28.3
Single-layer (4.5 in × 3 in)	
0 m/s	84.8
1 m/s	61.6
2.5 m/s	53.1
θ_{jc}	20.3
θ_{jb}	1.1

10. Static characteristics

Table 11. Static characteristics

$3.15\text{ V} \leq V_{DD} \leq 3.45\text{ V}$; $T_{amb} = -40\text{ }^{\circ}\text{C}$ to $+85\text{ }^{\circ}\text{C}$, unless otherwise specified.

Symbol	Parameter	Conditions	Min	Typ ^[1]	Max	Unit
V_{DD}	supply voltage (core and external rail)		3.15	3.3	3.45	V
I_{DD}	supply current	Active mode		<tdb>		mA
		Standby mode	-	2	-	mA
All pins except VNTC, LP_VSUP, SCL, SDA						
I_{IL}	LOW-level input current	$V_I = 0\text{ V}$	-	0.5	10	nA
I_{IH}	HIGH-level input current	$V_I = V_{DD}$	-	0.5	10	nA
I_{OZ}	OFF-state output current	$V_O = 0\text{ V}$; $V_O = V_{DD}$	-	0.5	10	nA
V_O	output voltage	output active	0	-	V_{DD}	V
V_{IH}	HIGH-level input voltage		$0.7V_{DD}$	-	-	V
V_{IL}	LOW-level input voltage		-	-	$0.3V_{DD}$	V
V_{hys}	hysteresis voltage		-	0.4	-	V
V_{OH}	HIGH-level output voltage	$I_{OH} = -4\text{ mA}$	$V_{DD} - 0.4$	-	-	V
V_{OL}	LOW-level output voltage	$I_{OL} = 4\text{ mA}$	-	-	0.4	V
I_{OH}	HIGH-level output current	$V_{OH} = V_{DD} - 0.4\text{ V}$	-4	-	-	mA
I_{OL}	LOW-level output current	$V_{OL} = 0.4\text{ V}$	4	-	-	mA
I_{OHS}	HIGH-level short-circuit output current	$V_{OH} = 0\text{ V}$	^[3] -	-	-45	mA
I_{OLS}	LOW-level short-circuit output current	$V_{OL} = V_{DD}$	^[3] -	-	50	mA
VNTC (pin 24)						
$V_{low-temp}$	NTC low temperature switching point		-	0.73	-	V
$V_{high-temp}$	NTC high temperature switching point		-	0.56	-	V
LP_VSUP (pin 16)						
I_{OZ}	OFF-state output current	$V_O = 0\text{ V}$; $V_O = V_{DD}$;	-	0.5	10	nA
V_O	output voltage	output active	0	-	V_{DD}	V
V_{OH}	HIGH-level output voltage	$I_{OH} = -20\text{ mA}$	$V_{DD} - 0.4$	-	-	V
V_{OL}	LOW-level output voltage	$I_{OL} = 4\text{ mA}$	-	-	0.4	V
I_{OH}	HIGH-level output current	$V_{OH} = V_{DD} - 0.4\text{ V}$; $2.5\text{ V} \leq V_{DD} \leq 3.6\text{ V}$	20	-	-	mA
I_{OL}	LOW-level output current	$V_{OL} = 0.4\text{ V}$	4	-	-	mA
I_{OLS}	LOW-level short-circuit output current	$V_{OL} = V_{DD}$	^[3] -	-	50	mA
NFC_I²C-bus pins (pin 10, pin 11)						
V_{IH}	HIGH-level input voltage		$0.7V_{DD}$	-	-	V
V_{IL}	LOW-level input voltage		-	-	$0.3V_{DD}$	V
V_{hys}	hysteresis voltage		-	$0.05V_{DD}$	-	V

Table 11. Static characteristics ...continued

$3.15\text{ V} \leq V_{DD} \leq 3.45\text{ V}$; $T_{amb} = -40\text{ }^{\circ}\text{C}$ to $+85\text{ }^{\circ}\text{C}$, unless otherwise specified.

Symbol	Parameter	Conditions	Min	Typ ^[1]	Max	Unit
I_{OL}	LOW-level output current	$V_{OL} = 0.4\text{ V}$	3.5	-	-	mA
I_{OL}	LOW-level output current	$V_{OL} = 0.4\text{ V}$	20	-	-	mA
I_{LI}	input leakage current	$V_I = V_{DD}$	-	2	4	μA

[1] Typical ratings are not guaranteed. The values listed are at room temperature (25 °C), nominal supply voltages.

[2] $T_{amb} = 25\text{ }^{\circ}\text{C}$.

[3] Allowed as long as the current limit does not exceed the maximum current allowed by the device.

[4] To V_{SS} .

11. Package outline

HVQFN33: plastic thermal enhanced very thin quad flat package; no leads; 33 terminals; body 7 x 7 x 0.85 mm

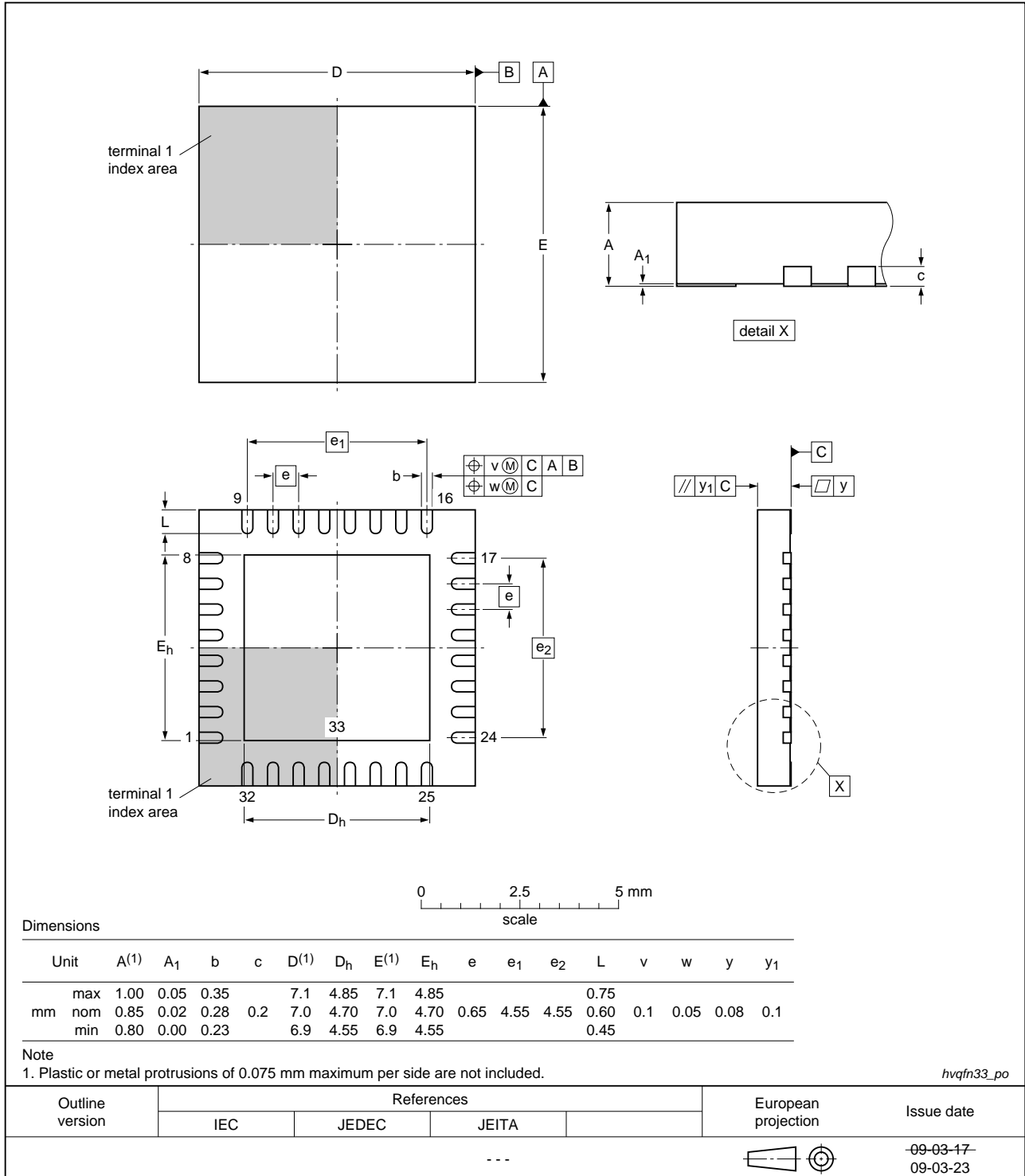

Fig 7. Package outline HVQFN33

12. Soldering

Footprint information for reflow soldering of HVQFN33 package

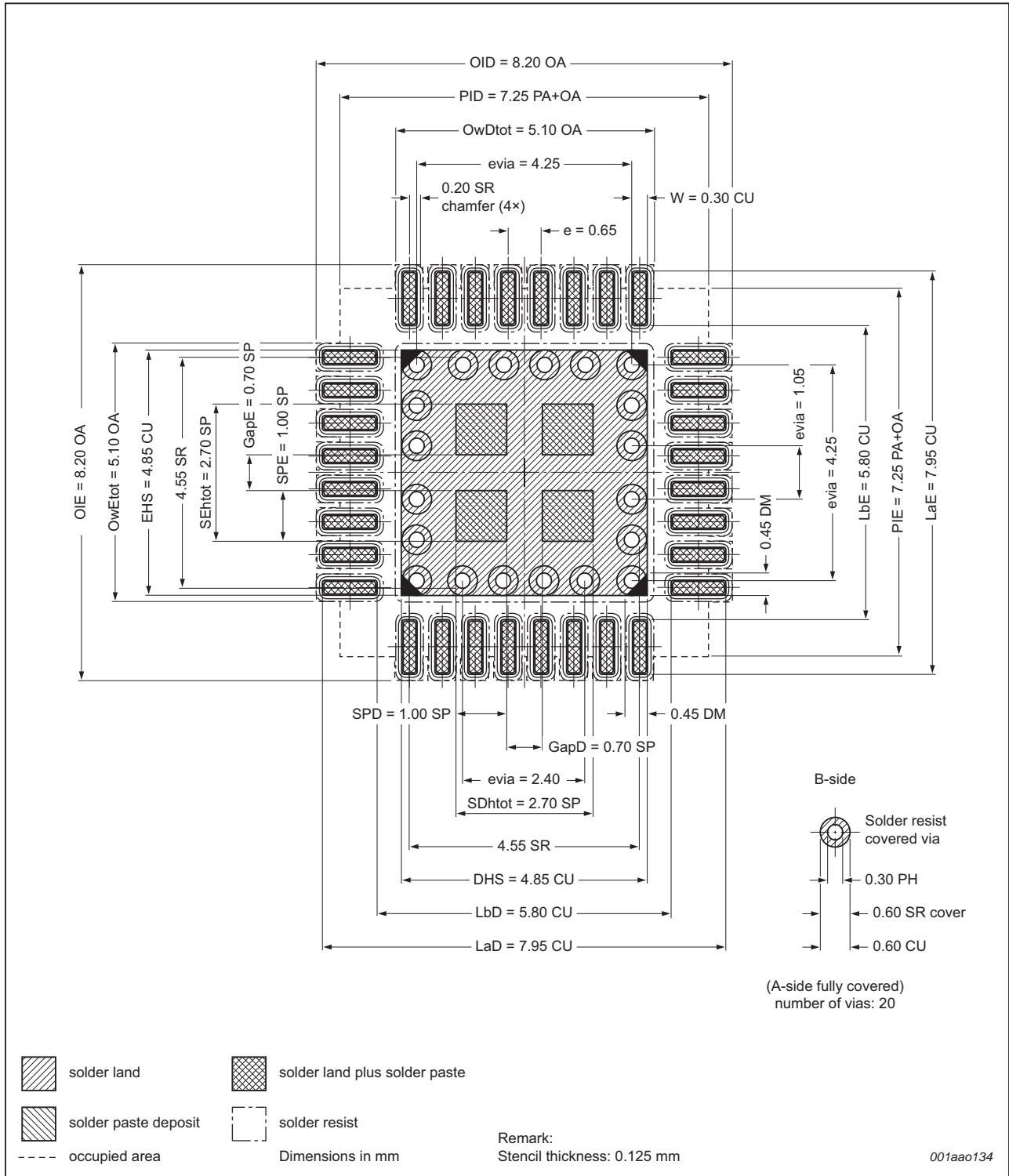

Fig 8. Reflow soldering of the HVQFN33 package

13. Abbreviations

Table 12. Abbreviations

Acronym	Description
ADC	Analog-to-Digital Converter
ASK	Amplitude Shift Keying
FOD	Foreign Object Detection
RC	Resistor-Capacitor
WPC	Wireless Power Consortium
HB	Half Bridge
NFC	Near Field Communication
PWM	Pulse Width Modulation
OTP	Over Temperature Protection
NTC	Negative Temperature Coefficient (Thermistor)

14. Revision history

Table 13. Revision history

Document ID	Release date	Data sheet status	Change notice	Supersedes
NXQ1TXA1 v.1	20140313	Objective data sheet	-	-

15. Legal information

15.1 Data sheet status

Document status ^{[1][2]}	Product status ^[3]	Definition
Objective [short] data sheet	Development	This document contains data from the objective specification for product development.
Preliminary [short] data sheet	Qualification	This document contains data from the preliminary specification.
Product [short] data sheet	Production	This document contains the product specification.

[1] Please consult the most recently issued document before initiating or completing a design.

[2] The term 'short data sheet' is explained in section "Definitions".

[3] The product status of device(s) described in this document may have changed since this document was published and may differ in case of multiple devices. The latest product status information is available on the Internet at URL <http://www.nxp.com>.

15.2 Definitions

Draft — The document is a draft version only. The content is still under internal review and subject to formal approval, which may result in modifications or additions. NXP Semiconductors does not give any representations or warranties as to the accuracy or completeness of information included herein and shall have no liability for the consequences of use of such information.

Short data sheet — A short data sheet is an extract from a full data sheet with the same product type number(s) and title. A short data sheet is intended for quick reference only and should not be relied upon to contain detailed and full information. For detailed and full information see the relevant full data sheet, which is available on request via the local NXP Semiconductors sales office. In case of any inconsistency or conflict with the short data sheet, the full data sheet shall prevail.

Product specification — The information and data provided in a Product data sheet shall define the specification of the product as agreed between NXP Semiconductors and its customer, unless NXP Semiconductors and customer have explicitly agreed otherwise in writing. In no event however, shall an agreement be valid in which the NXP Semiconductors product is deemed to offer functions and qualities beyond those described in the Product data sheet.

15.3 Disclaimers

Limited warranty and liability — Information in this document is believed to be accurate and reliable. However, NXP Semiconductors does not give any representations or warranties, expressed or implied, as to the accuracy or completeness of such information and shall have no liability for the consequences of use of such information. NXP Semiconductors takes no responsibility for the content in this document if provided by an information source outside of NXP Semiconductors.

In no event shall NXP Semiconductors be liable for any indirect, incidental, punitive, special or consequential damages (including - without limitation - lost profits, lost savings, business interruption, costs related to the removal or replacement of any products or rework charges) whether or not such damages are based on tort (including negligence), warranty, breach of contract or any other legal theory.

Notwithstanding any damages that customer might incur for any reason whatsoever, NXP Semiconductors' aggregate and cumulative liability towards customer for the products described herein shall be limited in accordance with the *Terms and conditions of commercial sale* of NXP Semiconductors.

Right to make changes — NXP Semiconductors reserves the right to make changes to information published in this document, including without limitation specifications and product descriptions, at any time and without notice. This document supersedes and replaces all information supplied prior to the publication hereof.

Suitability for use — NXP Semiconductors products are not designed, authorized or warranted to be suitable for use in life support, life-critical or safety-critical systems or equipment, nor in applications where failure or malfunction of an NXP Semiconductors product can reasonably be expected to result in personal injury, death or severe property or environmental damage. NXP Semiconductors and its suppliers accept no liability for inclusion and/or use of NXP Semiconductors products in such equipment or applications and therefore such inclusion and/or use is at the customer's own risk.

Applications — Applications that are described herein for any of these products are for illustrative purposes only. NXP Semiconductors makes no representation or warranty that such applications will be suitable for the specified use without further testing or modification.

Customers are responsible for the design and operation of their applications and products using NXP Semiconductors products, and NXP Semiconductors accepts no liability for any assistance with applications or customer product design. It is customer's sole responsibility to determine whether the NXP Semiconductors product is suitable and fit for the customer's applications and products planned, as well as for the planned application and use of customer's third party customer(s). Customers should provide appropriate design and operating safeguards to minimize the risks associated with their applications and products.

NXP Semiconductors does not accept any liability related to any default, damage, costs or problem which is based on any weakness or default in the customer's applications or products, or the application or use by customer's third party customer(s). Customer is responsible for doing all necessary testing for the customer's applications and products using NXP Semiconductors products in order to avoid a default of the applications and the products or of the application or use by customer's third party customer(s). NXP does not accept any liability in this respect.

Limiting values — Stress above one or more limiting values (as defined in the Absolute Maximum Ratings System of IEC 60134) will cause permanent damage to the device. Limiting values are stress ratings only and (proper) operation of the device at these or any other conditions above those given in the Recommended operating conditions section (if present) or the Characteristics sections of this document is not warranted. Constant or repeated exposure to limiting values will permanently and irreversibly affect the quality and reliability of the device.

Terms and conditions of commercial sale — NXP Semiconductors products are sold subject to the general terms and conditions of commercial sale, as published at <http://www.nxp.com/profile/terms>, unless otherwise agreed in a valid written individual agreement. In case an individual agreement is concluded only the terms and conditions of the respective agreement shall apply. NXP Semiconductors hereby expressly objects to applying the customer's general terms and conditions with regard to the purchase of NXP Semiconductors products by customer.

No offer to sell or license — Nothing in this document may be interpreted or construed as an offer to sell products that is open for acceptance or the grant, conveyance or implication of any license under any copyrights, patents or other industrial or intellectual property rights.

Export control — This document as well as the item(s) described herein may be subject to export control regulations. Export might require a prior authorization from competent authorities.

Non-automotive qualified products — Unless this data sheet expressly states that this specific NXP Semiconductors product is automotive qualified, the product is not suitable for automotive use. It is neither qualified nor tested in accordance with automotive testing or application requirements. NXP Semiconductors accepts no liability for inclusion and/or use of non-automotive qualified products in automotive equipment or applications.

In the event that customer uses the product for design-in and use in automotive applications to automotive specifications and standards, customer (a) shall use the product without NXP Semiconductors' warranty of the product for such automotive applications, use and specifications, and (b)

whenever customer uses the product for automotive applications beyond NXP Semiconductors' specifications such use shall be solely at customer's own risk, and (c) customer fully indemnifies NXP Semiconductors for any liability, damages or failed product claims resulting from customer design and use of the product for automotive applications beyond NXP Semiconductors' standard warranty and NXP Semiconductors' product specifications.

15.4 Trademarks

Notice: All referenced brands, product names, service names and trademarks are the property of their respective owners.

I²C-bus — logo is a trademark of NXP B.V.

16. Contact information

For more information, please visit: <http://www.nxp.com>

For sales office addresses, please send an email to: salesaddresses@nxp.com

17. Contents

1	General description	1
2	Features and benefits	1
3	Applications	1
4	Ordering information	1
5	Block diagram	3
6	Pinning information	5
6.1	Pinning	5
6.2	Pin description	6
7	Functional description	7
7.1	Functional overview	7
7.2	Configuration options	7
7.3	Safety features	8
7.3.1	Foreign Object Detection	8
7.3.2	Thermal protection	10
7.3.3	Receiver end power transfer	11
8	Limiting values	12
9	Thermal characteristics	13
10	Static characteristics	14
11	Package outline	16
12	Soldering	17
13	Abbreviations	18
14	Revision history	18
15	Legal information	19
15.1	Data sheet status	19
15.2	Definitions	19
15.3	Disclaimers	19
15.4	Trademarks	20
16	Contact information	20
17	Contents	21

Please be aware that important notices concerning this document and the product(s) described herein, have been included in section 'Legal information'.

© NXP Semiconductors N.V. 2014.

All rights reserved.

For more information, please visit: <http://www.nxp.com>

For sales office addresses, please send an email to: salesaddresses@nxp.com

Date of release: 13 March 2014

Document identifier: NXQ1TXA1